

Development of a Rechargeable Electric Fan

*Ben Festus, Amodu F. R., Basse E. N.

Physics/Electronics Option (Science Laboratory Technology Department.), The Federal Polytechnic Ede, Osun State, Nigeria

Corresponding Author: Ben Festus,

Abstract: Nigeria is a country plagued with erratic power supply that has lingered on for decades. A major feature of the Dry Season in Nigeria is thermal discomfort which is more pronounced at night due to lack of electricity from the Power Holding Company of Nigeria to operate AC powered electric fans. This research work describes the development of a rechargeable electric fan that operates on a 240V AC power source as well as a rechargeable 12V DC battery power source. The system consists of a 12V DC motor, fan blade, charging circuit, power supply unit and fabricated housing. When fully charged, the fan operates effectively well for 22 minutes after which the performance starts to fall. Charging the 12V lead acid battery used in this work requires 9hrs 15mins for complete charge. The charging circuit also incorporates a float charge and battery overcharge protector. The developed electric fan was housed in a fabricated steel housing unit. The fabricated fan compared well in terms of efficiency and functionality with the imported commercial types.

Keywords: Electric fan, rechargeable electric fan, 12V dc motor

Date of Submission: 30-08-2017

Date of acceptance: 25-09-2017

I. INTRODUCTION

Nigeria has two climatic seasons which are dry and wet season. The dry period is usually from November to March while the wet season is from April to October every year. One of the challenges associated with the dry season is thermal discomfort which can lead to increase sweating and dehydration as the relative humidity becomes low during this period owing to increase evaporation. At night, heat waves build up in homes owing to convection current. This has an adverse health impact on humans resulting from raised body temperature such as dehydration, heat cramps, heat oedema (swelling), heat syncope (fainting), heat rash, cardiovascular and respiratory diseases, amongst others (Wiley 2012).

The electric fan helps to reduce these adverse health impacts caused by heat waves by getting air to people occupying a building, office, residential complex, shops or public places. However, the problem of erratic power supply that has bedevilled the country for several decades has further aggravated health challenges caused by heat waves (source). There is however a Global clamour for alternative sources of energy or renewable energy. This would in no small way help militate against the challenge posed by erratic power supplies as more homes would have access to clean and cheap energy to tackle the menace of heat waves. The underlying challenge is that fans found in homes or public places are AC powered. It therefore becomes imperative to develop and fabricate an electric fan that is DC powered.

An electric fan is a machine used to create a flow within a fluid, typically a gas such as air (Cory, 2010). Electric fan gives personal thermal comfort as it is difficult to sleep comfortably in a hot weather without it. The fan known as the "Punkah" in India was first used in early 500BC (Moggyland, 2010). Schulyer Wheeler was however adjudged to have invented the first electric fan produced from two unshielded blades, powered by an electric motor and housed in a protective cage using the principle of home cooling (Finolex, 2012).

A typical electric fan is made up of blades, hub, motor, switch, guard, mount and a power cord and works on the principle of electromagnetic induction. Fans produce flows with high volume and low pressure. It circulates the air and provides the pressure required to push it. Missouri (2010) observed that the most important design consideration of an electric fan is that it must impact to the air stream a uniform velocity and pressure over its entire area. According to Wiley (2012), fans do not cool the ambient air but draw cooler air from outside especially when placed in an open space.

As earlier highlighted, to meet the yearning demand of renewable energy, there is therefore the need to develop an electric fan that is DC powered. In this work, a DC powered electric fan has been developed with the aid of a DC motor. The fan works on the principle of electromagnetic induction with the coil situated in the DC motor induced by the application of a direct current. The electric current from a DC source is connected to the motor's electric terminals which feed electric power into the commutator through a pair of loose connector called brushes (Sinclair, 2000). The DC battery used for this work is a 12V lead acid batter which is rechargeable.

II. MATERIALS AND METHODS

Principle of Operation

The functional block diagram of rechargeable electric fan system is shown in Figure 1. The regulated power supply was designed using a step-down transformer and rectifying unit. The regulated power supply is used to convert AC signal to DC for use by the battery charging circuit. The battery charging unit comprises of electronic components such as capacitors, resistors, op-amps, diodes, thyristors, transistors and light emitting diodes (LED).

The battery charging circuitry has sections that monitors and detects wrong battery polarity connector, float charge, full charge indicator status and an overcharge protection. The electronic components are arranged in such a way as to achieve a steady float charge on the batter when in use. The battery charger circuit is responsible for charging the 12V lead acid battery incorporated in this work at a rechargeable current of 1mA. The battery used has a cycle voltage of 14.4 – 15V, a standby voltage of 13.5 – 14V and an initial current that is less than 2.1A. The output comprises of a DC motor to which a fan blade is connected. Current is supplied to the DC motor by the battery, which in turn energizes the fan blade for clockwise rotation thereby producing the desired cooling effect.

Circuit Design and Development

The electronic circuit of the rechargeable electric fan is depicted in Figure 2. The op-amp i.e. LM324 was used as a comparator to monitor voltage at the terminal of the 12V lead acid battery. This voltage was compared with a reference threshold of 2.5V set by a thyristor (TL431). When the battery has a voltage less than the threshold, the op-amp triggers an output that causes the circuit to commence charging by supplying a current of 1mA. A yellow LED was used to indicate charging status.

When the battery is fully charged, the circuit triggers a float charge indicator (i.e. a red LED) to alert the user. The circuit also has some form of in-built intelligence that prevents the battery from overcharging thereby ensuring that the battery voltage is maintained at the specified standby voltage. Any attempt to exceed this standby voltage, the op-amp cuts supply to the battery.

The entire process is repeated when the battery voltage falls below the threshold. The charging circuit is also equipped with a wrong battery polarity connection detecting circuitry. This circuit was incorporated owing to the fact that wrong polarity connection shortens life span of a battery thereby reducing its efficiency greatly. A red LED is used to indicate this occurrence.

A metal structure casing unit was fabricated for the rechargeable electric fan by cutting, bending and assembly processes. A metal plate of thickness 2mm, length 120cm, and breadth 8cm was cut and bent into a square shape of equal length. The metal sheet was joined together using a welding rod and its accessories. The unit houses the fan blade, the DC motor, the battery, transformer and the charging circuit. The casing was painted with silver color for durability and to minimize the effect of humidity and corrosion. Figure 3 shows the developed rechargeable electric fan unit.

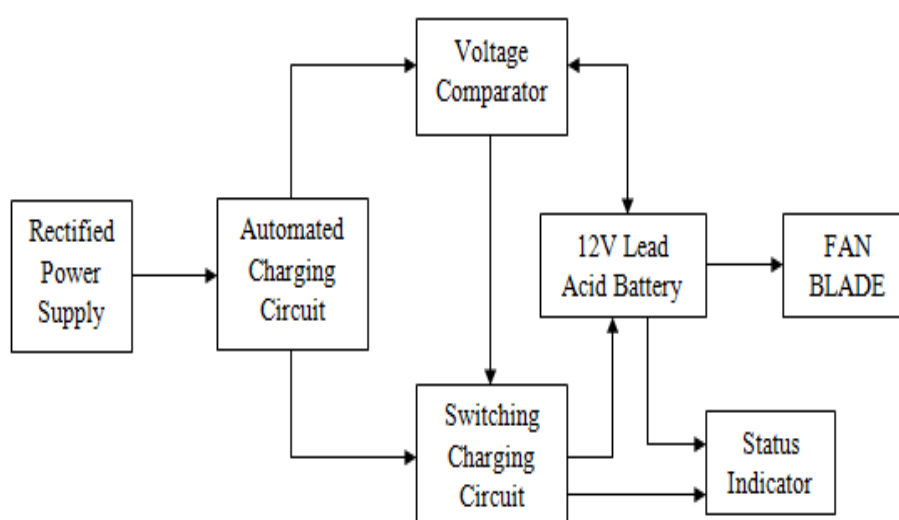

Figure 1: Block Diagram of the Rechargeable Electric Fan

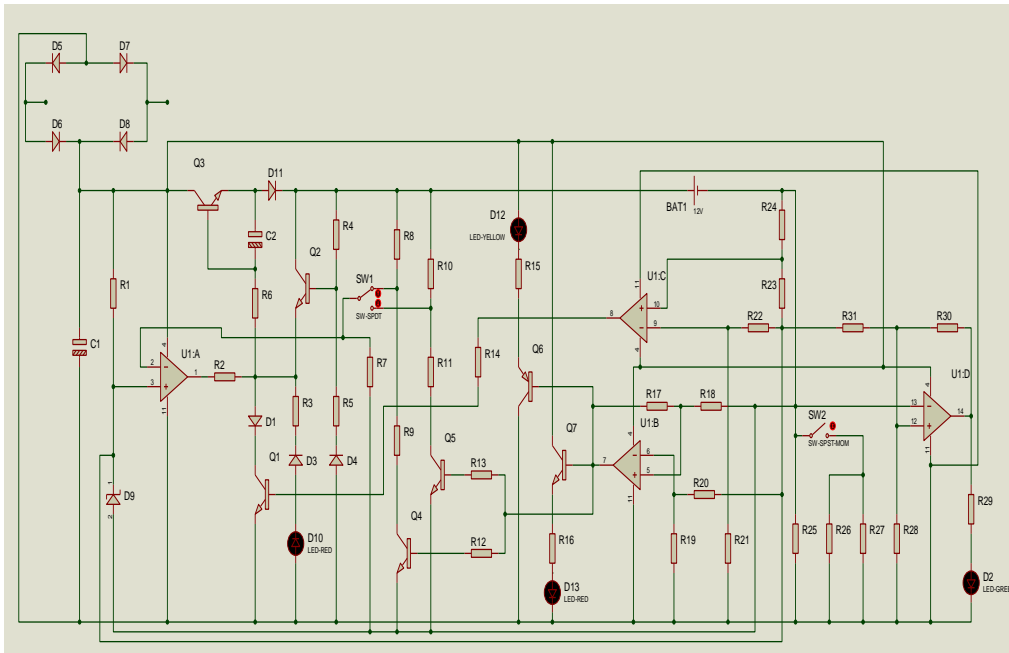

Figure 2: Automated Charging Circuit Diagram



Figure 3: Prototype of the Developed Rechargeable Electric Fan

III. RESULTS AND DISCUSSION

The developed rechargeable electric fan was subjected to some basic electronic test such as continuity test, earthing test, and efficiency test. The continuity test indicated free flow of current within the circuit. The earthing test showed absence of leakage current on the body of the fabricated fan thereby eliminating likely hood of electric shock. The efficiency test was used to determine the charging time of the battery as well as direction of rotation of the fan blade during operation.

From the efficiency test conducted, the fan blade performed well in a clockwise motion compared to the anticlockwise motion. Wrong polarity on the other hand caused the fan blade to rotate in anticlockwise motion producing no cooling effect to the user. The fan operated optimally well for 17 minutes, after which the speed of rotation gradually declined indicating a fast and steady drop in the current supplied by the lead acid battery. The fan blade stopped at exactly 5 minutes later, thereby bringing the total operating time to 22 minutes. The speed of the fan blade however increased when an AC power source was connected to the system. The battery charging indicator also came on. It took the battery 9hrs 15mins to become fully charged.

IV. CONCLUSION

The fabricated rechargeable electric fan is novel in that it uses locally available materials for its operation. Sixty percent of the materials used in this work are recycled waste, for example, the fan blade was salvaged from a damaged and abandoned car radiator unit at a nearby local mechanic workshop. The fabricated rechargeable electric fan incorporates a battery that can be easily recharged and monitored to prevent over charging and wrong polarity connections. The fabricated electric fan can only blow air in one direction since it does not rotate. On the average, it performed well when compared to the imported commercial ones.

REFERENCES

- [1]. Wiley Ian (2012); Adverse Effects of Heat on AC Motor Protection. Schweitzer Engineering Laboratories. INC, Camelot
- [2]. Cory William (2010); Farms and Ventillation. Transactions of the American Institutes of Electrical Engineers 61 (12): CPC Press, America, pp. 864
- [3]. Moggyland D. (2010); Tangential Blower with Motor. Cambridge University Press, Graford.
- [4]. Finolex Kaita (2012); History of Electrical Fan. Howard W., Sams and Co., United Kingdom
- [5]. Missouri S. (2010); Necessity for Uniform Flow and Pressure of a Fan Blade. A Manual for Student in Advanced Classes. Longman, London
- [6]. Sinclair I. R. (2000); Passive Component for Circuit Design, The Johns Hopking University Press, Baltimore.