

# Fast Charging Method for Electric Vehicles Based On Cascaded Multilevel Converter

**Dr.A.John Dhanaseely,**  
**R.MONISHA,**  
*Department Of EEE*  
*IFET College of Engineering*

## ABSTRACT

In order to charge the electric vehicles within a small phase of time and the charging time of the electric vehicle depends on the battery and charging point. The proposed system is the cascaded multilevel converter for charging the electric vehicle using the five-level topology in an efficient manner. The fast charging method for charging the vehicle from the single-phase supply, the voltage can be boosted in each level where all the five levels are cascaded. The voltage can be boosted by the cascaded multilevel converter to enhance the performance of the system and increases the life of the battery. The hardware setup and analysis are shown in this paper.

**KEYWORDS** – cascaded multilevel converter, five level topology, electric vehicle and fast charging.

---

Date of Submission: 24-09-2022

Date of Acceptance: 08-10-2022

---

## 1. INTRODUCTION

Electric vehicles play a significant role in the automobile industry. The advantages of electric vehicles are the better for the environment, less pollution problems and there is no fuel is used and no emissions. The major problem faced in electric vehicle is charging period which takes 8 to 11 hours from the empty to full with a charging point. In the past decades, the dynamic wireless power transfer method which has been done by shrinking the charging time duration, battery size and weight. The efficiency as well as power factor plays an important criterion for making power transfer capability and to reduce the operating cost [1]. The cascaded multilevel converter has wide range of applications in high and medium power applications handle the high power and high current capabilities. It produces the more voltage in each unit can be generated and the major characteristics of cascaded multilevel converter is low switching frequency [2].

The three levels cascaded multilevel converter for the charging and discharging control to balance the overall voltage balance control strategy and the energy can be throughout the topology applied in electric vehicles [3]. The reconfigurable LLC converter established on the five switch bridge method to charge the deeply depleted on-board battery packs to obtain the efficiency [4]. The charging time can be decreased by the characterization of LiFePO<sub>4</sub> batteries and the charging performance can be improved but the cost of the batteries is high [5]. To maintain the energy in the battery cells by the hybrid method cascaded multilevel converter in addition to the battery energy board [6].

The multilevel converter is used for reducing the switching element and produces the multilevel output by the single-phase T-type converter. To produce the multiple outputs by the single input source and increases the achievement of the electric vehicle [7]. The existence of the battery can be enhanced by the modular converter [8]. The multi-resonant eliminates both the low and high-frequency current ripple in the battery. It produces an immense range output of 100V to 430V for charging the electric vehicle applications can be done by the single-phase bi-directional AC-DC converter strategy [9]. The elimination of harmonic distortion of the low order harmonics by using of H-bridge converter method [10].

In the proposed system, the cascaded method of H-bridge multilevel converter established at the five-level topology which is used to boost the input voltage, taken from the single phase supply. By boosting the voltage in each level, the performance is improved and the life of the battery increases. The simulation results are done with the MATLAB software.

## 2. EXISTING SYSTEM

In an existing system, a hybrid method of cascaded multilevel converter on three-level cells to generate additional voltage levels in each cell along with the energy can be maintained effectively in the battery cells. It can be obtained after the mixture of effective clamped method of Three-Level strategies and an inverting H-bridge method. Here, all the three levels are cascaded together by the series connection of the H-bridge and each level having separate dc sources. The output ac voltage can be obtained in each level and it could be approximately ideal sinusoidal with the less cascaded units. The output voltage can feed to the motor vehicle with the help of an inverter. The experiments and results are shown in the existing system.

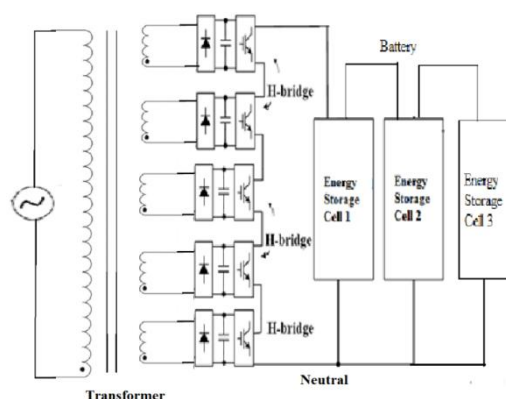

Fig.1.cascaded multilevel converter positioned on five-level topology

## 3. PROPOSED SYSTEM

In the proposed system, the cascaded multilevel converter depending on five- level topology to produce more voltage in each level with respect to the input voltage from the single-phase supply and the energy can be managed in each level in an effective manner. In this topology, all the five-level is cascaded together by the series link of the H-bridgeconverter. Each level consists of four MOSFET switches, inductance and capacitance. The inductance and capacitance play a significant role in the act as the filter to eliminate the ripples and stabilize the voltage in each level. The energy can be maintained in the each level with the help of capacitance. The main objective of the suggested system is to charge the battery of the electric vehicles within a small phase of time (three to four hours).

## 4. Analysis and Results

The simulation results of the five-level topology based on the cascaded multilevel converter is different from the existing system. The output can be achieved by the MATLAB Software and the analysis can be shown in this paper. In the simulation process, the output voltage, capacitor current, input voltage and pulses generated by the switches can be shown in this paper separately.

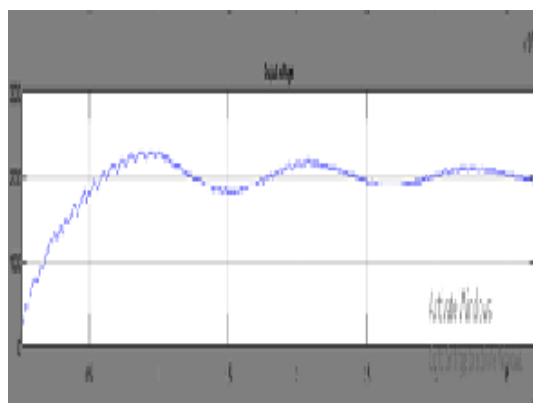

Fig.2.Output Voltage

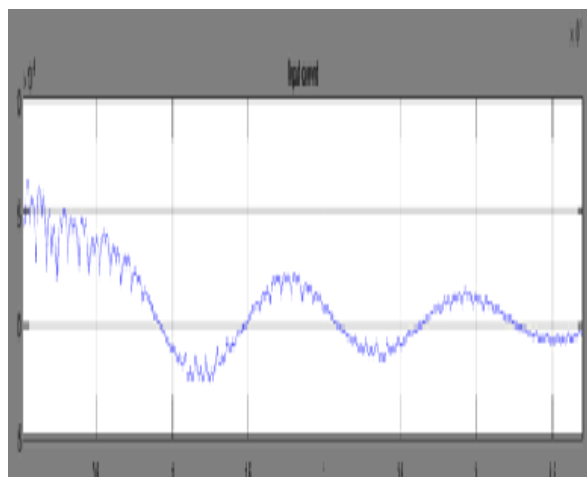

Fig.3.Input Current

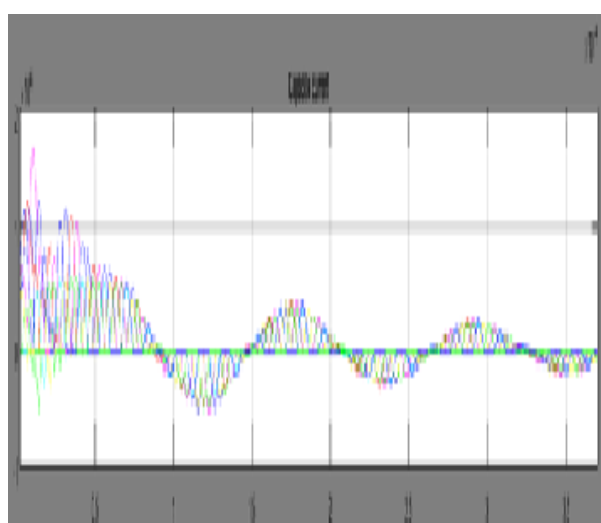

Fig.4.Capacitor current

**BLOCK DIAGRAM**

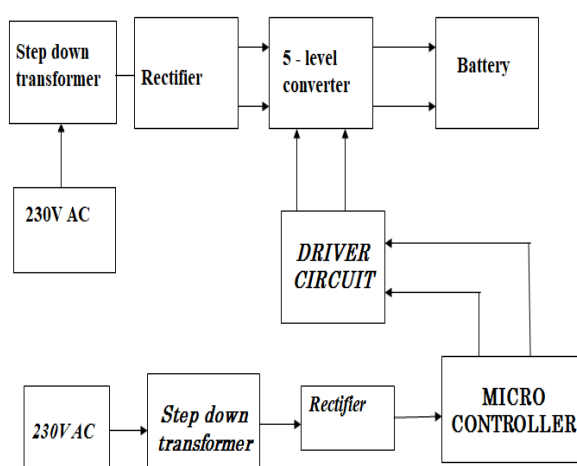

Fig.6.Block diagram of hardware experimental setup of 5 level converter

In these two transformers are used. One is stepped down the 230V to 12V. The 12V is feed to the rectifier which converts the ac to dc. The rectifier consists of a capacitor and voltage regulator which eliminates the unwanted noise and making the voltage more stable. The gain of the rectifier is given to the converter. Another one is stepped down 230V to 12V which is feed to the bridge rectifierconsists of the capacitor and

voltage regulator which is used to convert the 12V to 5V. The 5V is feed to the microcontroller. The microcontroller has On/Off switch which is used to operate the switches in the cascaded H-bridge converter. Finally, the output voltage is five times increases with respect to the input voltage which is shown by the multimeter. For example, the input voltage is 12V which is boosted with the help of cascaded multilevel converter to enhance the input voltage is five times increases to get an output up to 60V.

## HARDWARE

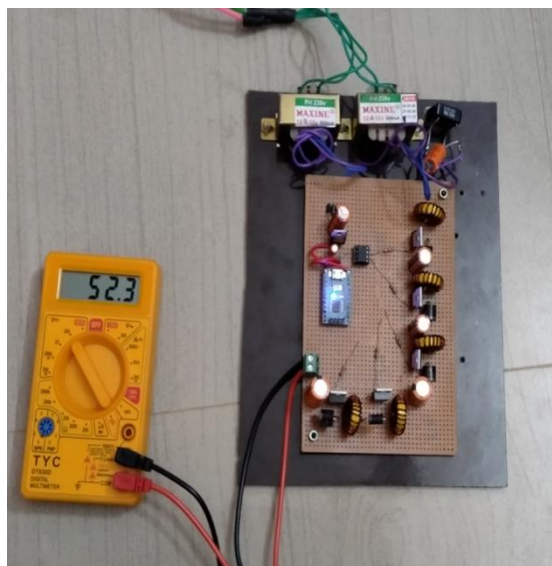

Fig 7: Hardware Setup

## 5. CONCLUSION

The proposed system is fast charging method for electric vehicles based on cascaded multilevel converter is able to reduce the charging time of the electric vehicles. To charge the electric vehicles within to three to four hours and enhances the life of the battery. It is the fast charging method for the electric vehicles from the single-phase supply. The cascaded multilevel converter is mainly focusing the boost he voltage which is taken from the single phase supply to improve the performance of the system. It also improves the output quality and handles high power. These are done with the simulation results in MATLAB software.

## REFERENCES

- [1]. C.-E. Kim, J.-I. Baek, and J.-B. Lee, "High-Efficiency Single-Stage LLC Resonant Converter for Wide-Input-Voltage Range," *IEEE Trans. Power Electron.*, vol. 33, no. 9, pp. 7832–7840, Sep. 2018.
- [2]. J. Deng, S. Li, S. Hu, C. C. Mi., and R. Ma, "Design methodology of LLC resonant converters for electric vehicle battery chargers," *IEEE Trans. Veh. Technol.*, vol. 63, no. 4, pp. 1581–1592, May 2014.
- [3]. Z. Liu, B. Li, F. C. Lee, and Q. Li, "High-Efficiency High-Density Critical Mode Rectifier/Inverter for WBG-Device-Based On-Board Charger," *IEEE Trans. Ind. Electron.*, vol. 64, no. 11, pp. 9114–9123, Nov. 2017.
- [4]. H. Wang, S. Dusmez, and A. Khaligh, "Maximum Efficiency Point Tracking Technique for LLC – Based PEV Chargers Through Variable DC Link Control," *IEEE Trans. Ind. Electron.*, vol. 61, no. 11, pp. 6041–6049, 2014.
- [5]. H. Wang, S. Dusmez, and A. Khaligh, "A novel approach to design EV battery chargers using SEPIC PFC stage and optimal operating point tracking technique for LLC converter," in 2014 IEEE Applied Power Electronics Conference and Exposition, pp. 1683–1689.
- [6]. N. Kim, K. Kim, J. Choi, and C.-W. Kim, "Adaptive frequency with power-level tracking system for efficient magnetic resonance wireless power transfer," *Electronics Letters*, vol. 48, pp. 452–454, 2012.
- [7]. D. Patil, M. K. McDonough, J. M. Miller, B. Fahimi, and P. T. Balsara, "Wireless power transfer for vehicular applications: overview and challenges," *IEEE Transactions on Transportation Electrification*, vol. 4, pp. 3–37, 2018.
- [8]. Y. Ye, K. W. E. Cheng, and Y. P. B. Yeung, "Zero-current switching switched-capacitor zero-voltage-gap automatic equalization system for series battery string," *IEEE Trans. Power Electron.*, vol. 27, no. 7, pp. 3234–3242, July 2012.
- [9]. J. Dixon et al., "Asymmetrical multilevel inverter for traction drives using only one DC supply," *IEEE Trans. Veh. Technol.*, vol. 59, no. 8, pp. 3736–3743, Oct. 2016.
- [10]. S. M. M. Sangdehi, S. Hamidifar and N. C. Kar, "A novel bidirectional DC/AC stacked matrix converter design for electrified vehicle Applications," *IEEE Trans. Veh. Technol.*, vol. 63, no. 7, pp. 3038–3050, Sept. 2014.