

## **Power Factor Correction and Comparison of Converter Topologies for Srm Drive**

E SAIDULU\*, J RANGA\*\*

*\*,\*\*Department of EEE, SreeDattha Institute of Engineering & Science*

---

**Abstract:** Recently, Switched reluctance motor (SRM) has become an important in various applications. When SRM is Operated as generator, it becomes as Switched Reluctance Generator (SRG), which is widely used in aeronautical industries and primarily as wind generator in wind based energy generating system. In this paper it gives information regarding various converter topologies of the switched reluctance motor drive and has been briefly explained. on the basis of Phase current waveform, Fourier analysis and total harmonic distortion the various converter topologies has been simulated and The simulation of various converter topologies of Switched reluctance motor drive has been done using P-SPICE. A new converter for switched reluctance motor drives is proposed, which is cost effective.

In this paper a new method is proposed, which is used for component sharing, thus it significantly reduces half of the component cost. This component sharing converter topology is a modification of the conventional asymmetric bridge converter for switched reluctance motor drives. The requirements of switched reluctance motor drives on Converters and the operation of the component sharing converter are analyzed using Matlab/Simulink. Furthermore, the simulation results confirm the feasibility of the proposed converter. As extension to this work power factor correction is also considered in this work. As SRM is a DC drive we need DC supply and rectifier is used to get DC output from AC input. In this work we are improving power factor at input side.

**Keywords:** *Switched Reluctance Motor (SRM), Converter, PSpice Analysis.*

---

### **I. INTRODUCTION**

The switched reluctance motors (SRMs) have a simple and robust structure with low inertia and direct drive capability, thus SRM drives are applicable to many industrial fields. However, the converter configuration of SRM drive is not standard. Numerous converters for SRM drives were proposed, developed and used in industrial applications [1]. The main considerations in the design of a single-switch-per-phase converter for a switched reluctance motor drive with particular attention to the Choice of converter topology, the type of switching devices, the normalized rating of the power devices, and input filter design [2].

A typical switched reluctance motor drive essentially consists of four basic components: Power Converter, Control Logic Circuit, Position Sensor and Switched Reluctance Motor. The phase windings of a doubly salient switched reluctance motor are fed with unipolar pulses of current from a suitable power converter to control the speed and torque of the motor [4]. The essential features of the power switching circuit for each phase of the switched reluctance motor comprises of two parts: A controlled switch to connect the voltage source to the coil windings in order to build up the current, when the switch is turned off there should be an alternative path for the current to flow, since the trapped energy in the phase winding can be used for the other strokes. In addition to this, it protects the switch from the high current produced by the energy trapped in the phase winding [8].

SRM has become an important alternative in Various applications both within the industrial and domestic markets, namely as a motor showing good mechanical reliability, high torque-volume ratio and high efficiency, plus low cost. As a generator SRM find its application in the aeronautical industries and in integrated applications primarily as wind generator in wind based energy generating system. In this paper the various topologies viz. resonant, bifilar, split dc supply, R-dump, asymmetric bridge Converter with respect to voltage rating, number of switches per phase, THD and applications are compared. The phase current response with respect to time and frequency are also compared.

Among these converters, it's observed that the asymmetric bridge converter is the most popular and best performed one. In this paper, a new and cost effective converter topology, which is the modified asymmetric bridge topology, is developed. It inherits the advantages of the asymmetric bridge topology. Furthermore, it has higher utilization of switch devices. Thus, the proposed converter circuit can be designed with more compact configuration, smaller size and lower cost.

## II. COMPARISON OF SRM TOPOLOGIES

Converter	Voltage rating	Switching devices	THD	Application
Resonant	$>V_{dc}$	$N+1$	0.261	High frequency
Bifilar	$(1+a)V_{dc}$	$N$	0.28	Low power, Low voltage
Split Supply	dc	$N$	0.27	Fractional Hp motors,
R-dump	$V_{dc} - (I_p + \Delta I)R$	$N$	0.264	Low speed, Low switching frequency
Asymmetric	$V_{dc}$	$2N$	0.277	High power

## III. COMPONENT SHARING CONVERTER

### A. Component sharing converter topology

Fig 1 illustrates the component sharing converter circuit for four phase SRM drive. It can be observed that the component sharing converter needs eight IGBT modules and four diodes, in comparison to eight IGBT modules and eight diodes in asymmetric bridge converters. On the other hand, each phase is controlled by different switching devices. It is helpful to reduce the temperature rise and extend the lifetime of IGBT components.

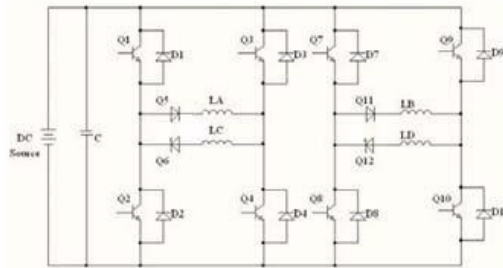

Fig. 1. Component sharing converter topology for four-phase SRM

According to the principle of operation of SRM drives, the energy conversion process may occur simultaneously in two adjacent phases, in order to acquire high starting torque and low torque ripple. This mode of operation may cause a current overlap [1]. In the developed converter, therefore, alternate phases are grouped together, such as Phase A and Phase C, or Phase B and Phase D, shown in Fig 1. This allows independent current control of each phase with overlapping currents not exceeding one phase cycle duration.

### B. Operation of component sharing converter

For the developed converter, the operation of each phase Includes three modes; they are charging, freewheeling and Discharging. For the sake of simplicity of the illustration, the operation of two phases in a group is analyzed in the following discussion. Fig 2, Fig 3 and Fig 4 depict the operations of phase A and PhaseC in group, respectively.

#### Mode 1: Charging

Referring to Fig 2, if the switching devices Q1, Q4 and diode Q5 are turned on, the DC link voltage is then applied to Phase A and the current rises rapidly in the phase winding. In the same way, if the switching devices Q2, Q3 and diode Q6 are switched on, Phase C is charged through the switches Q2, Q3 and diode Q6.

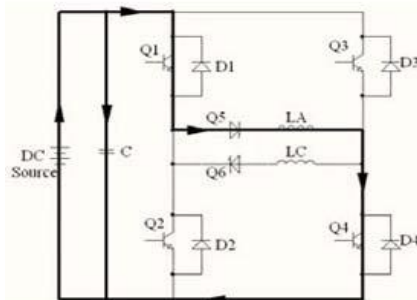

Fig. 2. Charging Operation of phase-A

Mode 2: Freewheeling

It can be seen from Fig 3, if the switch Q1 is turned off and the switch Q4 and diode Q5 are still on, then current circulate through the switch Q4, and forward-biased diodes Q5, D2. In this mode, there is no energy transfer between phase winding and DC source. Similarly, Phase C freewheels through switch Q2 and the diode Q6, D4 when the switch Q3 is turned off and the switch Q2 and diode Q6 are still on.

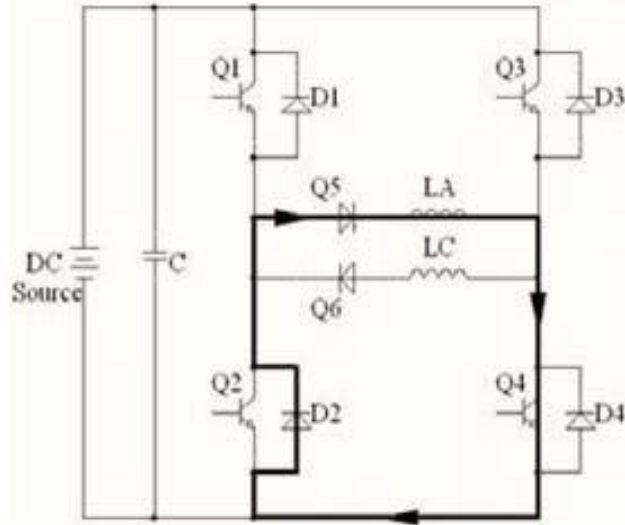

Fig. 3. Freewheeling Operation of phase-A

Mode 3: Discharging

As is shown in Fig 4, the switches Q1 and Q4 are turned off and Q5 is still forward biased in this mode. Consequently, PhaseA discharges to the DC link capacitor, through D2, D3 and Q5. In the same way, Phase C discharges to the DC link capacitor through Q6 and the diodes D1 and D4 if the switches Q2 and Q3 are switched off and diode Q6 is still on.

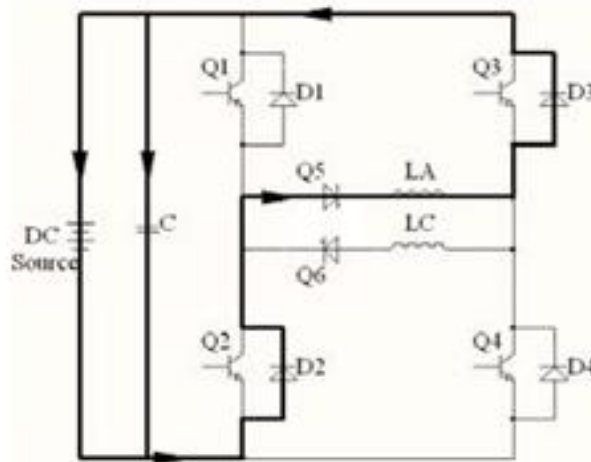

Fig. 4. Discharging Operation of phase-A

**IV. SRM DRIVE USING COMPONENT SHARING CONVERTER**

In order to observe the performance of component sharing Converter for SRM drives, the simulation based on MATLAB/SIMULINK was carried out. Fig 5 and Fig 6 shows the developed simulation block diagram in MATLAB/SIMULINK. The simulation results for flux, phase current, torque, and speed variation with respect to time are shown in Fig 7.

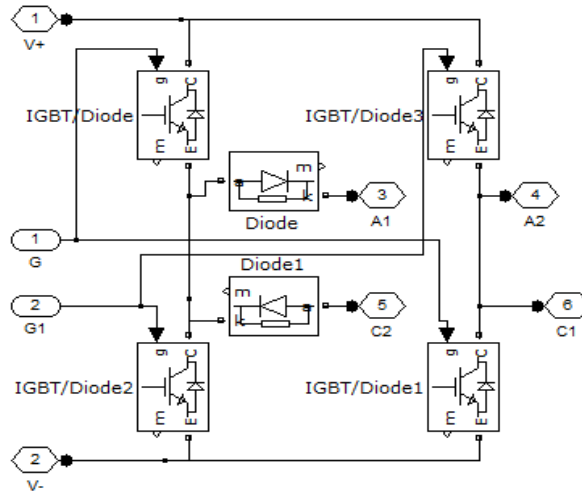

Fig. 5. Converter Circuit.

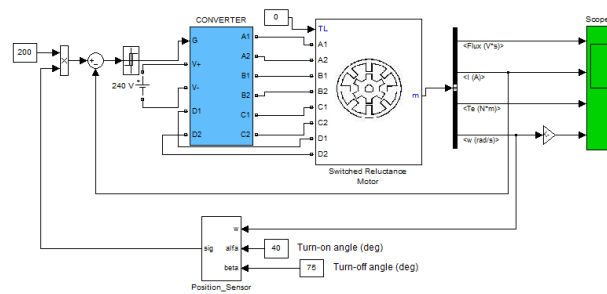
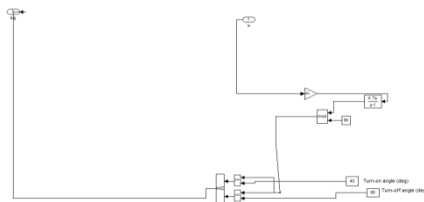
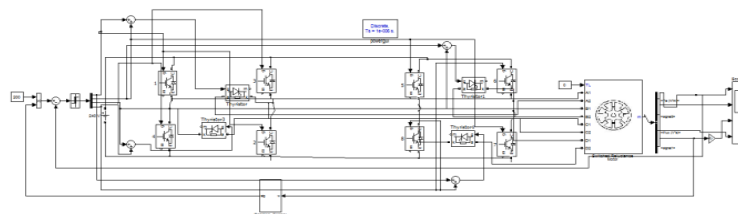

Fig. 6. Simulation diagram of component sharing converter based SRM drive.

Simulink model



Proposed SRM:



As for Phase A, for example, the phase current rises rapidly when the switches Q1, Q4 and diode Q5 are turned on. Then, the switch Q1 is turned on or off during the hysteresis current control. The switch Q4 and diode Q5 are always turned on during the hysteresis current control to provide the path for freewheeling. Finally, the switches Q1 and Q4 are switched off when the conduction angle reaches the specified value. The energy stored in Phase A discharges to the DC link capacitor through Q5 and the diodes D2 and D3, and the

phase current declines to zero fast. It can be observed that the simulation current waveform demonstrates that the proposed converter for SRM drives can be used to implement the hysteresis current control.

In the same way, the single pulse voltage control and the PWM voltage control are also accomplished in the component sharing converter.

### **SIMULATION WAVEFORMS:**

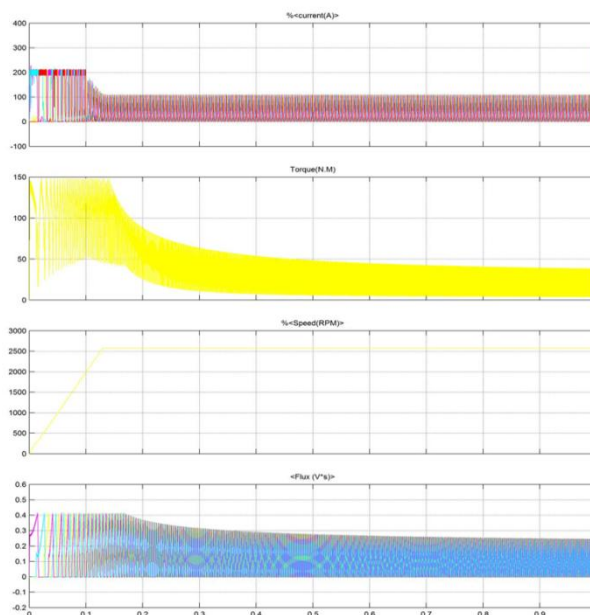

**Fig. 7.** Simulation waveforms.

From the analysis and simulation, therefore, the salient merits of the proposed converter can be summarized as: (1) It has the higher utilization of switch compared to traditional asymmetric bridge converters; (2) The charging, freewheeling and discharging modes can be accomplished; (3) The single pulse voltage, hysteresis current and PWM voltage controls can be implemented; (4) The converter is capable of the positive, negative and zero voltage output capability; The drawback of this converter is that it requires an even number of machine phases, but now-a-days most of the SRM drives are designed to have an even number of machine phases, so this drawback will not restrict its applicability in practice.

### **V. CONCLUSION**

In this paper, various converter topologies of the switched reluctance motor drive have been studied. A comparison between the various converter topologies has been done on the basis of Phase current waveform, fourier analysis and total harmonic distortion. The simulation of various converter topologies of switched reluctance motor drive has been done using PSpice and a new and cost effective converter topology for switched reluctance motor drives has been proposed. Compared to the conventional asymmetric bridge converter, the proposed one using component sharing is more compact and has higher utilization of power switches and lower cost, without degradation in performance. The developed converter has three conventional operating modes that are charging, freewheeling and discharging modes. Hence, the single pulse voltage control, the hysteresis current control and the PWM voltage control are implemented in the developed converter. The simulation in Matlab/Simulink has demonstrated the performance of the proposed converter. As a result, this study provides the valuable converter for SRM drives in industrial applications and also for SRG in wind based energy generators. The proposed new method arrangement allows the reduction in circuit components by nearly 50%. This converter can be applied for all the even number of phases of the switched reluctance motor drive and discharging modes. Hence, the single pulse voltage control, the hysteresis current control and the PWM voltage control are implemented in the developed converter. The simulation in Matlab/Simulink has demonstrated the performance of the proposed converter. As a result, this study provides the valuable converter for SRM drives in industrial applications and also for SRG in wind based energy generators. The proposed new method arrangement allows the reduction in circuit components by nearly 50%. This converter can be applied for all the even number of phases of the switched reluctance motor drive.

### REFERENCES

- [1]. Slobodan Vukosavic, Victor R.Stefanovic, "SRM Inverter Topologies: A Comparative Evaluation," IEEE Transactions on Industry Applications, vol.27, no.6, pp.1034-1047, 1991.
- [2]. R. Krishnan and P. Materu, "Design of a Single-Switch-Per-Phase Converter for Switched Reluctance Motor Drives," IEEE Transactions on Industrial Electronics, vol. 37, no.6, pp469-476, 1990.
- [3]. C. Pollock and B.W. Williams, "A Unipolar Converter for a Switched Reluctance Motor," IEEE Transactions on Industry Applications, vol. 26,no. 2, pp. 222-228, 1990.
- [4]. C. Pollock and B.W. Williams, "Power Converter Circuits for SwitchedReluctance with the Minimum Number of Switches," IEE Proc., vol. 137, Pt. B, no. 6, pp. 373-384, 1990.
- [5]. R.M. Davis and R.J. Blake, "Inverter Drive for Switched Reluctance Motor Circuits and Component Ratings," IEE Proc., pp. 126-136, 1981.
- [6]. Muhammad H. Rashid, Spice for Power Electronic Circuits, Pearson Prentice Hall, 2009.
- [7]. R. Krishnan, Switched Reluctance Motor Drives: Modeling, Simulation, Analysis, Design and Applications, CRC Press, 2001.
- [8]. Rajiv Kumar, Mohd. Ilyas, Neelam Rathi, "PSpice Simulation of Split DC Supply Converter," IJEAT, Issn: 2231-1963, 2012.
- [9]. Zhang.Z, Cheung.N.C, Cheng K.W.E, Xue.X.D, Lin J.K, and Bao Y.J,"Analysis and Design of a Cost Effective converter for Switched Reluctance Motor drives Using Component Sharing," International Conference on Power Electronics Systems and Applications, 2012.