

## Novel Three-Level Converter for Power-Factor-Correction and Connected To DC Drive

B Padma\*, J Ranga\*\*

\*,\*\* Department of EEE, Sree Dattha Institute of Engineering & Science

---

**Abstract:** Harmonic pollution and low power factor in power systems caused by power converters have been of great concern. To overcome these problems several converter topologies using advanced semiconductor devices and control schemes have been proposed. In this paper a new three-level ac-dc single-stage converter that can operate with standard phase-shift pulse width modulation is proposed. The ac-dc power supplies with transformer isolation are typically implemented with some sort of input power factor correction (PFC) to comply with harmonic standards such as IEC 1000-3-2. There are three techniques to satisfy these standards. One of them is adding passive filter elements to the traditional passive diode rectifier/LC filter input combination; the resulting converter is very bulky and heavy due to the size of the low-frequency inductors and capacitors. In this paper, the operation of the converter is explained, and its feasibility is confirmed with experimental results obtained from a prototype converter. Finally, the efficiency of the new converter is compared with that of the converter shown. In extension we connect a DC motor as a load to the proposed converter and observe the performance. The advantage of the proposed converter is resulting an output of 3 level which reduces stress of voltage. The proposed system is a single stage conversion where DC-DC conversion is not needed.

**Keywords:** PFC-power factor correction, VAR, KVAR, SSPFC, PSM, TL.

---

### I. INTRODUCTION

#### 1.1 POWER FACTOR:

Power factor is defined as the cosine of the angle between voltage and current in an ac circuit. There is generally a phase difference  $\phi$  between voltage and current in an ac circuit.  $\cos \phi$  is called the power factor of the circuit. If the circuit is inductive, the current lags behind the voltage and power factor is referred to as lagging. However, in a capacitive circuit, current leads the voltage and the power factor is said to be leading. In a circuit, for an input voltage  $V$  and a line current  $I$ ,  $VI \cos \phi$  –the active or real power in watts or kW.  $VI \sin \phi$  –the reactive power in VAR or kVAR.  $VI$  – the apparent power in VA or kVA. Power Factor gives a measure of how effective the real power utilization of the system is. It is a measure of distortion of the line voltage and the line current and the phase shift between them. Power Factor = Real power(Average)/Apparent power Where, the apparent power is defined as the product of rms value of voltage and current.

##### 1.1.1 LINEAR SYSTEMS:

In a linear system, the load draws purely sinusoidal current and voltage, the current and voltage, hence the power factor is determined only by the phase difference between voltage and current. i.e.  $PF = \cos \theta$

##### 1.1.2 POWER ELECTRONIC SYSTEMS:

In power electronic system, due to the non-linear behaviour of the active switching power devices, the phase angle representation alone is not valid. A non linear load draws typical distorted line current from the line. The PF of distorted waveforms is calculated as below: The Fourier representation for line current  $i_s$  and line voltage  $v_s$  are given by,

$$i_s = I_{DC} + \sum I_n \sin(n\omega t + \theta)$$

$$v_s = V_{DC} + \sum V_n \sin(n\omega t + \theta)$$

#### 1.2 HARMONICS:

Switching converters of all types produce harmonics because of the non-linear relationship between the voltage and current across the switching device. Harmonics are also produced by —conventionally equipment including:

- 1) Power generation equipment(slot harmonics).
- 2) Induction motors (saturated magnetics).
- 3) Transformers (overexcitation leading to saturation)
- 4) Magnetic-ballast fluorescent lamps (arcing) and
- 5) AC electric arc furnaces.

All these devices cause harmonic currents to flow and some devices, actually, directly produce voltage harmonics.

## II. IPROPOSED CONCEPT

The ac–dc power supplies with transformer isolation are typically implemented with some sort of input power factor correction (PFC) to comply with harmonic standards such as IEC 1000-3-2 [1]. There are three techniques to satisfy these standards. One of them is adding passive filter elements to the traditional passive diode rectifier/LC filter input combination; the resulting converter is very bulky and heavy due to the size of the low-frequency inductors and capacitors [2]. Another method is using an ac–dc boost converter in the front-end rectifying stage to perform active PFC for most applications. The ac–dc boost converter shapes the input line current as an almost

sinusoidal shape with a harmonic content compliant with agency standards. Using active PFC, however, increases the cost and complexity of the overall two-stage converter because an additional switching converter must be implemented [2]. This has led to the emergence of single-stage power-factor-corrected (SSPFC) converters. There have been numerous publications about SSPFC converters, particularly for low-power ac–dc flyback and forward converters [3]. Research on the topic of higher power ac–dc single-stage full-bridge converters, however, has proved to be more challenging, and thus, there have been much fewer publications. Several single-stage ac–dc full-bridge current-fed converters have been proposed [4]; these converters have a boost inductor connected to the input of the full-bridge circuit. A three-level (TL) voltage-fed ac–dc single-stage PWM converter was proposed in and is shown in Fig. 2.1. This topology does not have the drawbacks of previously proposed single-stage converters because of its TL structure. The PWM method that was used to operate the converter is shown in Fig. 2.2. As can be seen, this PWM method is not standard phaseshift PWM (PWM) and is therefore not found in commercially available integrated circuits.

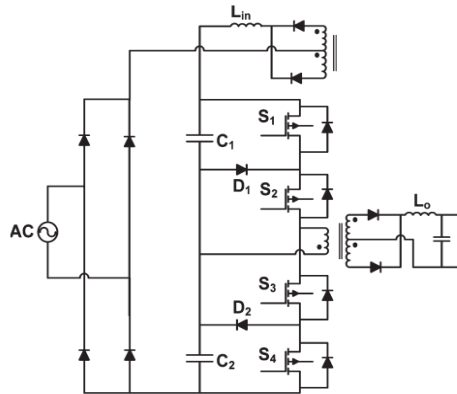


Fig. 2.1. Single-stage TL ac–dc converter.

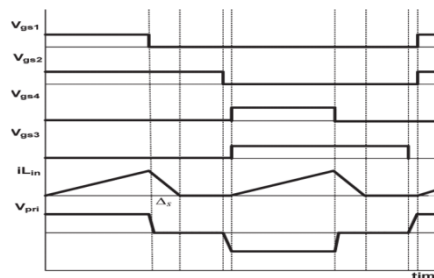


Fig. 2.2. Typical waveforms describing the modes of operation.

In this letter, the operation of the converter is explained, and its feasibility is confirmed with experimental results obtained from a prototype converter. Finally, the efficiency of the new converter is compared with that of the converter shown in Fig. 2.1.

### 2.2. PSM TECHNIQUE FORTL SINGLE-STAGE CONVERTERS

The proposed converter, shown in Fig. 2.3, integrates an ac–dc boost PFC into a TL dc/dc converter[5]. It is almost the same as the converter proposed in and with a flying capacitor between two clamping diodes. The PFC is performed by using an auxiliary winding taken from the main transformer that acts like a switch that turns on and off in an appropriate manner. Typical converter waveforms are shown in Fig. 2.4, and equivalent circuit diagrams that show the converter’s modes of operation with phase-shift modulation (PSM) are shown in Fig. 2.5. The diode rectifier bridge output is replaced by a rectified sinusoidal source, and the thick lines represent the paths of current conduction

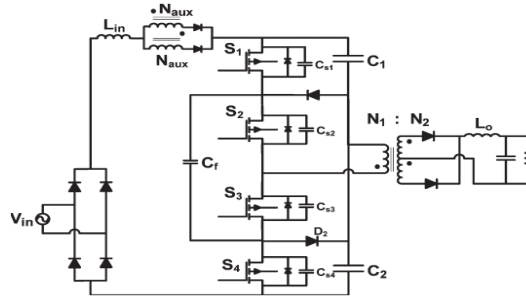


Fig. 2.3. Proposed single-stage TL ac-dc converter.

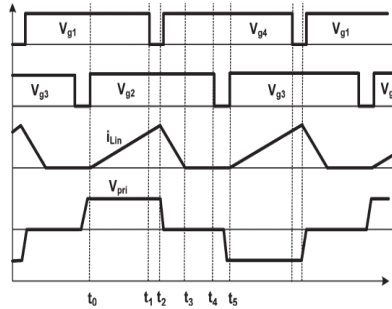


Fig. 2.4. Typical waveforms for the proposed converter.

The converter has the following modes of operation.

- 1) Mode 1 ( $t_0 < t < t_1$ ) [Fig. 2.5(a)]: During this mode, switches S1 and S2 are ON, and energy from dc bus capacitor C1 is transferred to the output load. Since the auxiliary winding generates a voltage ( $N_{aux}/N_1=2$ ) that is equal to the total dc-link capacitor voltage (sum of C1 and C2), the voltage across the input inductor is the rectified supply voltage, and thus, the input inductor current starts rising.
- 2) Mode 2 ( $t_1 < t < t_2$ ) [Fig. 2.5(b)]: In this mode, S1 is OFF and S2 remains ON. Capacitor C1 charges and capacitor C4 discharges through C until C4, the output capacitance of S4, clamps to zero [6] [7]. The energy stored in the input inductor during the previous mode starts to be transferred into the dc-link capacitors. This mode ends when S4 turns on with zero-voltage switching (ZVS).
- 3) Mode 3 ( $t_2 < t < t_3$ ) [Fig. 2.5(c)]: In Mode 3, S1 is OFF and S2 remains ON. The energy stored in the input inductor during Mode 1 is completely transferred into the dc-link capacitors [8]. The amount of stored energy in the input inductor depends upon the rectified supply voltage. This mode ends when the input inductor current reaches zero. Also, during this mode, the load inductor current freewheels in the secondary of the transformer.

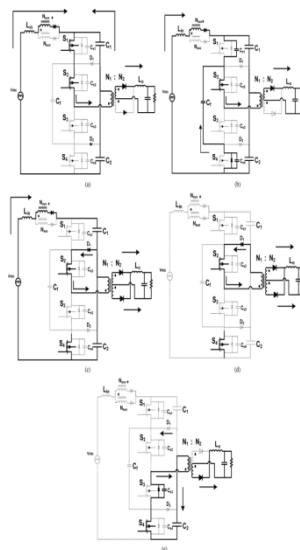
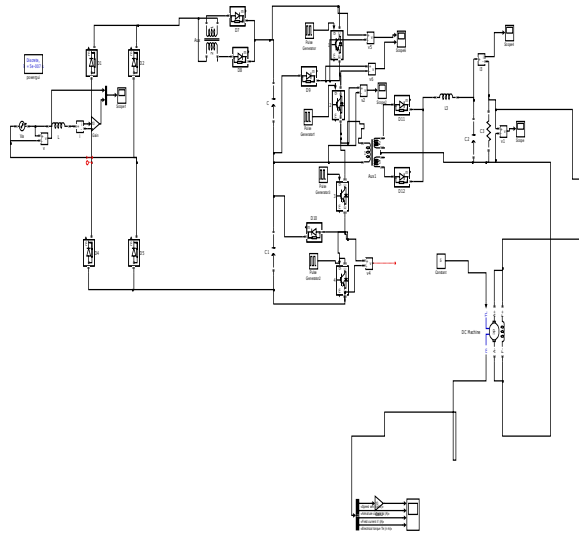


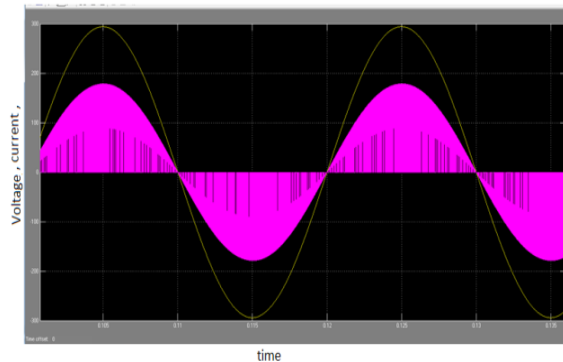
Fig. 2.5 .Modes of operation. (a) Mode 1 ( $t_0 < t < t_1$ ). (b) Mode 2 ( $t_1 < t < t_2$ ). (c) Mode 3 ( $t_2 < t < t_3$ ). (d) Mode 4 ( $t_3 < t < t_4$ ). (e) Mode 5 ( $t_4 < t < t_5$ ).

- 4) Mode 4 ( $t_3 < t < t_4$ ) [Fig. 2.5(d)]: In this mode, S1 is OFF, the primary current of the main transformer circulates through diode D1 and S2, and the load inductor current freewheels in the secondary of the transformer [9].
- 5) Mode 5 ( $t_4 < t < t_5$ ) [Fig. 2.5(e)]: In this mode, S1 and S2 are OFF, and the current in the transformer primary charges capacitor C2 through the body diode of S3 and switch S4. This mode ends when switches S3 and S4 are switched on and a symmetrical period begins. In this mode, the load inductor current continues to transfer energy from the input to the output. It should be noted that the analysis and design of this converter are identical to that presented in for the converters shown in Fig. 2.1. Consequently, the analysis of the new TL single-stage converter is not presented here [10].

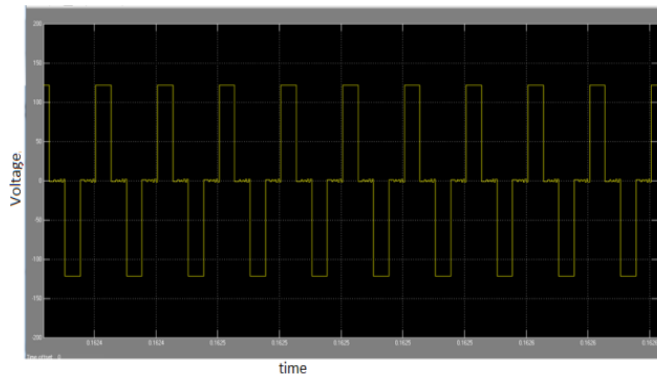


**Fig.3.6.**Circuit diagram for simulation

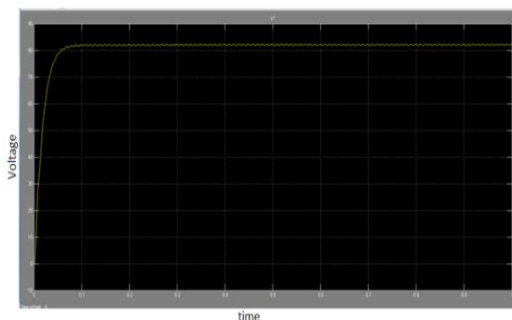
### III. MATLAB/SIMULINK RESULTS



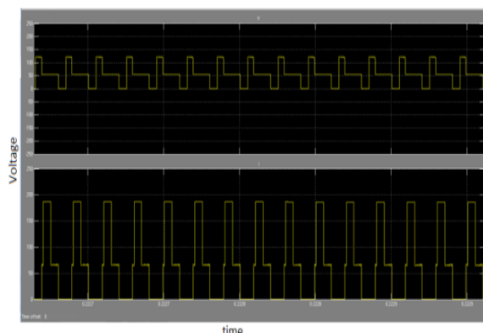
**Fig.3.1.**Power factor correction using single stage correction



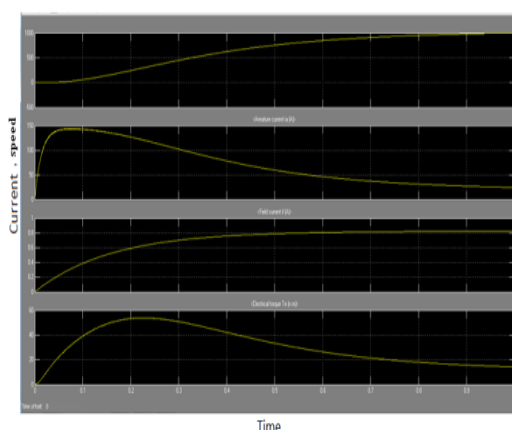
**Fig.3.2.**Three level voltage wave form



**Fig.3.3.**Pulsating Dc out put



**Fig.3.4.**Thyristor voltages



**Fig.3.5.**Performance characteristics of a dc shunt motor

#### IV. CONCLUSION

In this paper a new three-level ac–dc single-stage converter that can operate with standard phase-shift pulse width modulation is proposed. There are three techniques to satisfy these standards. One of them is adding passive filter elements to the traditional passive diode rectifier/LC filter input combination; the resulting converter is very bulky and heavy due to the size of the low-frequency inductors and capacitors. In extension we connect a DC motor as a load to the proposed converter and observe the performance. The advantage of the proposed converter is resulting an output of 3 level which reduces stress of voltage. The proposed system is a single stage conversion where DC-DC conversion is not needed.

#### REFERENCES

- [1]. D. D. C. Lu, D. K. W. Cheng, and Y. S. Lee, "Single-stage AC–DC power-factor-corrected voltage regulator with reduced intermediate bus voltage stress," *Proc. Inst. Elect. Eng.—Elect. Power Appl.*, vol. 150, no. 5, pp. 506–514, Sep. 2003.
- [2]. G. Moschopoulos, "A simple ac–dc PWM full-bridge converter with integrated power factor correction," *IEEE Trans. Ind. Electron.*, vol. 50, no. 6, pp. 1290–1297, Dec. 2003.
- [3]. S. Luo, W. Qiu, W. Wu, and I. Batarseh, "Flyboost power factor correction cell and a new family of single-stage ac/dc converters," *IEEE Trans. Power Electron.*, vol. 20, no. 1, pp. 25–34, Jan. 2005.
- [4]. Y. Jang, M. M. Jovanovic, and D. L. Dillman, "Soft-switched PFC boost rectifier with integrated ZVS two-switch forward converter," *IEEE Trans. Power Electron.*, vol. 21, no. 6, pp. 1600–1606, Nov. 2006.
- [5]. A. Lazaro, A. Barrado, M. Sanz, V. Salas, and E. Olias, "New power factor correction AC–DC converter with reduced storage capacitor voltage," *IEEE Trans. Ind. Electron.*, vol. 54, no. 1, pp. 384–397, Feb. 2007.

- [6]. D. D.-C. Lu, H. H.-C. Iu, and V. Pjevalica, "A single-stage ac/dc converter with high power factor, regulated bus voltage, and output voltage," *IEEE Trans. Power Electron.*, vol. 23, no. 1, pp. 218–228, Jan. 2008.
- [7]. S. K. Ki and D. D.-C. Lu, "Implementation of an efficient transformer-less single-stage single-switch ac/dc converter," *IEEE Trans. Ind. Electron.*, vol. 57, no. 12, pp. 4095–4105, Dec. 2010.
- [8]. H. Ma, Y. Ji, and Y. Xu, "Design and analysis of single-stage power factor correction converter with a feedback winding," *IEEE Trans. Power Electron.*, vol. 25, no. 6, pp. 1460–1470, Jun. 2010.
- [9]. H. J. Chiu, Y. K. Lo, H. C. Lee, S. J. Cheng, Y. C. Yan, C. Y. Lin, T. H. Wang, and S. C. Mou, "A single-stage soft-switching flyback converter for power-factor-correction applications," *IEEE Trans. Ind. Electron.*, vol. 57, no. 6, pp. 2187–2190, Jun. 2010.
- [10]. J. Zhang, D. D.-C. Lu, and T. Sun, "Flyback-based single-stage power factor correction scheme with time-multiplexing control," *IEEE Trans. Ind. Electron.*, vol. 57, no. 3, pp. 1041–1049, Mar. 2010.